



– Commander NV500

– Commander NV500 Eagle

Digital Day/Night Vision Scope



User Manual

CONTENTS

PRODUCT IMAGE	2
SPECIFICATIONS	
Commander NV500	3
Commander NV500 Eagle	4
Illuminator	6
Rangefinder(Optional)	6
PREPARING	
1.Unboxing	7
2.Power source	
2.1.Powered by Internal Battery	8
2.2.Powered by USB Type-C	8
3.Type-C port/Micro SD Card slot/Micro HDMI port/Reset	
3.1.Type-C Port	9
3.2.Micro SD Card Slot	10
3.3.Micro HDMI Port	10
3.4.Reset	11
4.Operation	
4.1.Diopter Adjustment	11
4.2.Eyecup Installation	11
4.3.Objective Lens Installation and Removal	12
4.4.Lens Recognition	13
4.5.Objective Focusing	13
4.6.Sunshade Installation	14
4.7.Mount Installation	14
5.Rangefinder(Optional)	
5.1 Installation	15
5.2 Operation	16
6. Illuminator	
6.1 Product Image	15
6.2 Illuminator Mounting	16
HOME SCREEN	18
MENU	20
PLAYBACK	40
FIRMWARE UPDATE	41
TROUBLESHOOTING	42



ATTENTION

When using a monocular, it may cause eye fatigue or temporary blindness, but recovery will occur after stopping use. Please note the following points when using a monocular :

I. Focusing

1. ****Correct Focusing****

- Before observing with a monocular, ensure that the monocular is correctly focused. Failure to do so may lead to excessive eye adjustment and visual fatigue. For example, when observing a distant target, slowly turn the focusing knob until the target appears clearly. Avoid prolonged viewing when the image is blurred, as the eyes will constantly adjust their muscles to see the image clearly, which may cause eye muscle strain.

2. ****Avoid Frequent Focusing****

- Do not change the focus too frequently, rapidly switching from one distance target to another and repeatedly focusing. This will put the ciliary muscles of the eyes in a frequent state of tension and relaxation. For instance, when observing birds in the sky and scenery on the ground, switching back and forth too quickly can easily lead to eye fatigue or even dizziness.

II. Duration of Observation

1. ****Limiting Continuous Observation Time****

- It is not advisable to use a monocular for an excessively long period of time continuously. Prolonged observation through a monocular can reduce the blinking rate of the eyes. Normally, people blink 15-20 times per minute, but during focused observation, this may decrease to just a few times per minute. This can lead to an uneven distribution of the tear film on the surface of the eyes, easily causing eye dryness. It is generally recommended to take a break of 2-3 minutes after 15-20 minutes of continuous observation, during which time you can look at distant natural scenery or close your eyes to rest.

2. ****Avoiding Prolonged Observation in Bright Light****

- If you are observing in a bright light environment (such as observing the sun, which is a very dangerous act and requires the use of specialized solar filters) or observing high-brightness targets for an extended period (such as objects in snowy landscapes due to the intense reflection of snow), the retina of the eyes is susceptible to damage. In such cases, the duration of observation should be more strictly limited, and appropriate shading devices or light filters should be used.

III. Observation Environment Aspects

1. ****Stable Observation Posture****

- Maintaining a stable observation posture is crucial. If the posture is unstable, the monocular is prone to shaking, causing the eyes to constantly adjust their gaze direction to track the target. For example, when holding a monocular, keep your arms stable or use auxiliary equipment such as a tripod. Unstable observation can cause extra strain on the eye muscles, leading to fatigue and discomfort.

2. ****Avoid Dust and Foreign Objects****

- When using a monocular, ensure that there is no dust, sand, or other foreign objects around the lenses and eyepiece. When using it in environments with heavy wind and dust, be particularly careful to protect the monocular and avoid foreign objects entering the eyepiece and coming into contact with the yes. If a foreign object enters the eye, do not rub it. Instead, rinse it with clean water as soon as possible or seek medical assistance.

PRODUCT IMAGE

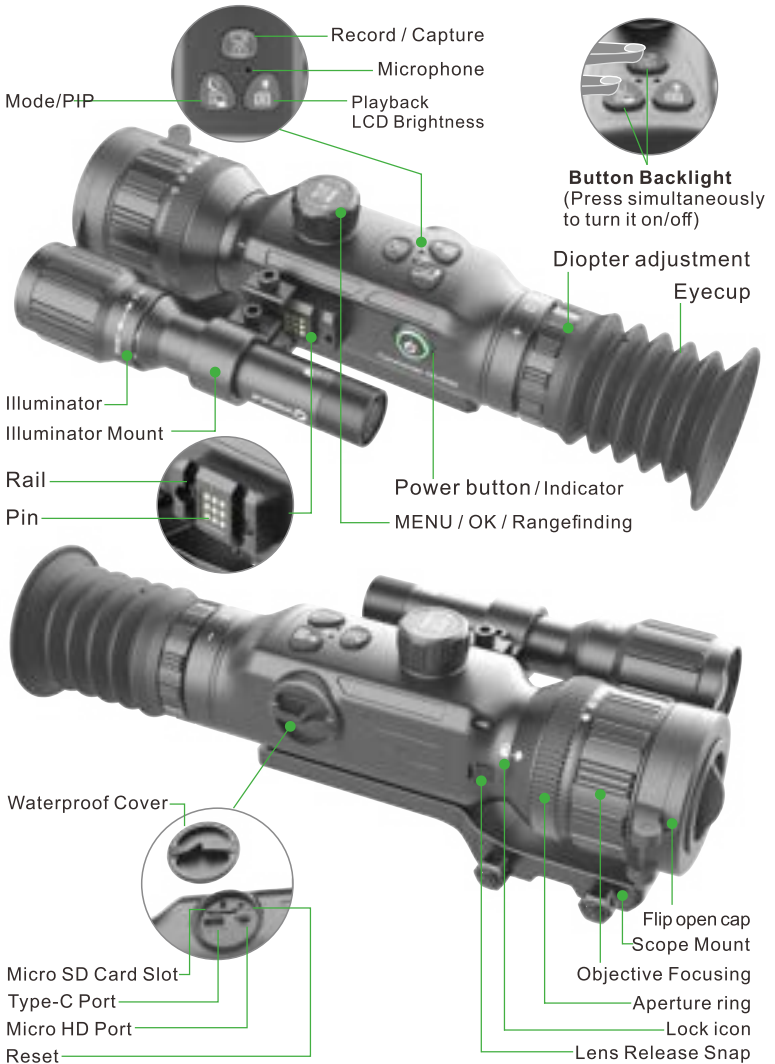

SPECIFICATIONS

— Commander NV500

Item	2-16X30	4-32X50	6-48X70
Type of sensor	Sony STARVIS CMOS Sensor		
Sensor resolution (pixels)	3864x2228		
Sensor sensitivity (lux)	0.0001		
Display type	LCOS		
Display resolution (pixels)	1280X960		
Objective lens(mm)	30mm	50mm	70mm
Relative aperture(D/f')	F1.3-10	F1.2	F1.8-10
Magnification	2-16	4-32	6-48
Lens diameter(mm)	30	50	70
Digital zoom	1-8X		
Field of view(HxV) Horizontal	9.9	5.8	4.26
Field of view(HxV) Vertical	5.47	3.2	2.38
Field of view(HxV) Diagonal	11.31	6.6	4.9
Field of view(m@100m)	17.3	11.6	7.44
Field of view(ft@100yd)	52.23	34.8	22.33
Focus range	3.82yd~Infinity	4.37yd~Infinity	4.37yd~Infinity
Eye relief(mm)	45~70		
Diopter adjustment(D)	-6~+2		
Reticle style	7		
Reticle color	White/Red/Green/Blue/ Dark green		
Position	6		

— Commander NV500 Eagle

Item	Eagle 1.5-12X30	Eagle 2-16X50	Eagle 4.5-36X70
Type of sensor	Sony STARVIS CMOS Sensor		
Sensor resolution (pixels)	3864x2228		
Sensor size (Inch)	1/1.8		
Sensor sensitivity (lux)	0.0001		
Display type	LCOS		
Display resolution (pixels)	1280X960		
Objective lens(mm)	30mm	50mm	70mm
Relative aperture(D/f')	F1.3-10	F1.2	F1.8-10
Magnification	1.5-12	2-16	4.5-36
Lens diameter(mm)	30	50	70
Digital zoom	1-8X		
Field of view(HxV) Horizontal	13.66	8.05	5.85
Field of view(HxV) Vertical	7.56	4.6	3.24
Field of view(HxV) Diagonal	15.58	9.4	6.7
Field of view(m@100m)	24.13	16.2	10.24
Field of view(ft@100yd)	72.38	44.1	30.73
Focus range	3.82yd~Infinity	4.37yd~Infinity	4.37yd~Infinity
Eye relief(mm)	45~70		
Diopter adjustment(D)	-6~+2		
Reticle style	7		
Reticle color	White/Red/Green/Blue/Dark green		
Position	6		

Mode	Day/Starry/Night		
Photo resolution	48M/24M/12M/8M		
Photo format	JPG		
Video resolution	4K 120fps/4K 60fps/4K 30fps		
Video format	MP4		
Storage	32 - 256Gb		
Detachable lens	YES		
Automatic lens recognition	YES		
Microphone	YES		
3D Gyroscope	YES		
Electronic compass	YES		
Built-in battery	YES		
External power supply	USB 5V $\overline{\text{---}}$ 2.4A Type-c		
Operating time(h)	6H		
Mount	Included		
Body material	Aluminum		
Accessory rail mount	Picatinny		
Waterproof rating	IP67		
Adjustment range(MOA)	330 MOA Windagex150 MOA Elevation		
Max recoil power(G)	1100		
Max recoil (Caliber)	.308		
Dimension	7.59*2.44*2.76in	7.96*2.49*2.8in	8.66*2.44*2.76in
Weight	1.6lb/0.73kg	1.68lb/0.76kg	1.74 lb / 0.79 kg
Warranty	2Years		

Illuminator

Item	IR850mini
Emitter	LED
IR wavelength	850nm
Equivalent IR power	8000mW
Power supply	Battery(Included)
Battery life	4~10H
IR distance	437yd/400m
Mount	Included
Brightness adjust	3 gears
Accessory rail mount	Picatinny
Waterproof rating	IPX6
Body material	Aluminum
Dimension(Body only)	5.67*1.49*1.49in
Weight(Body only)	0.26 lb / 0.12 kg

Rangefinder(Optional)

LRF detection range	5.5~1300yards
Red dot	Yes
Body material	Aluminum

NOTE: oneleaf.ai reserves the right to change the above specifications at any time without notice.

PREPARING

1. Unboxing

Package Contents:

- Commander NV500



- Rangefinder
(LRF version included)



- Illuminator



- Flip open cap



- 65mm Eyecup



- Type-C Cable



- Scope Mounts



- Micro SD Card



- Allen Wrench



- Lens Cloth



- O-ring



- Manual



- Warranty Card



2. Power source

2.1 Built-in Battery

The device comes with built-in rechargeable Li-ion battery. Please charge the device via 5V \equiv 2.4A charger.

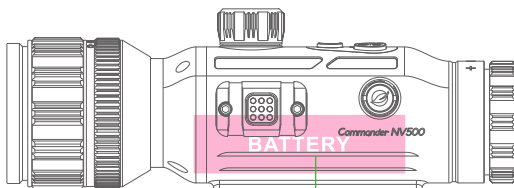

Built-in rechargeable Li-ion battery

2. 2. Powered by USB Type-C

- The NV500 includes a Type-C port. It can be found by unscrewing the waterproof cover on the right side of the device counterclockwise.



Type-C port

- Use the Type-C cable included in the package.
- Use a charger with an output port of 5V \equiv 2.4A or a power bank to power the device.

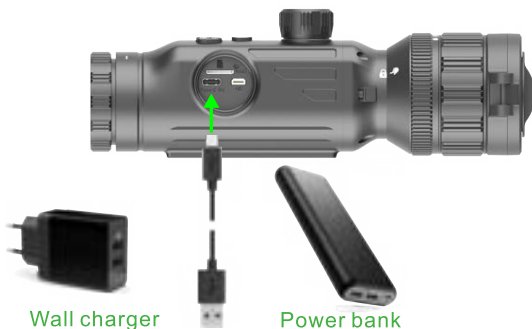

Wall charger

Power bank

NOTE

- Please use a charger or power bank with an output port of 5V=2.4A or above to power the device.
- When charging the device, it is recommended to power off the device.

3.Type-C Port/Micro SD Card Slot/Micro HD Port/Reset

Unscrew the waterproof cover on the right side of the device counterclockwise to expose the ports. Make sure all ports are not exposed to water after the waterproof cover is removed.

3.1Type-C Port

(1) Power the device.

(2) Charge the battery.

- If the device is turned off while charging, the indicator will be red at first and will go out when the device is fully charged.
- If the device is turned on while charging, the indicator light will be yellow at first, and it will turn green when the device is fully charged.



Red Indicator



Green Indicator





Yellow Indicator



- It takes 4 hours to charge the device when it is turned off.

(3)Data transmission.

- Connect the device to the computer via a Type-C cable. Press and hold  to power on , The computer will prompt that a removable disk has been detected.

A prompt box of  will pop up on the screen. Once the connection is established, photos and videos from the Micro SD card can be viewed on the computer.

- When the device is connected to a computer, the device will automatically shut down when the Type-C cable is unplugged.

NOTE

- Please use a charger or power bank with an output port of 5V=2.4A to power the device.
- It is recommended to turn off the device while charging.
- Make sure the device has a Micro SD Card installed before connecting the device to PC.

3.2 Micro SD Card Slot

- Install the Micro SD card:

Follow the icon instructions and use your finger to push it into the port in the correct direction until it locks into place.

- Remove the installed Micro SD card:

Gently press the Micro SD card and it will eject.



NOTE

- There is only one correct direction for the Micro SD card to be inserted. Do not force the card into the slot to avoid damaging the card and the device.
- When removing the installed Micro SD card, please do it slowly.
- Please use a Micro SD card with a read rate of C10 or higher and a capacity of 32-256Gb.
- Do not remove the Micro SD card during recording.

3.3 Micro HD Port

Connect the device to the monitor via the Micro HD cable and the monitor can display the captured images from the device in real time.



Micro HDMI



Monitor

NOTE

- The maximum output current of the Micro HDMI port is 5V=1000mA.

3.4 Reset

- If the device crashes, press the reset and the device will shut down directly.
- Press and hold  for 3s and the device will turn on.



4. Operation

4.1 Diopter Adjustment

The device's diopter adjustment accommodates a wide range of visual needs, ranging from myopia of 600 degrees to hyperopia of 200 degrees. You can adjust the diopter wheel to your eyesight until the display appears clearly in the viewfinder. Rotate the diopter wheel clockwise for myopia and counterclockwise for hyperopia.

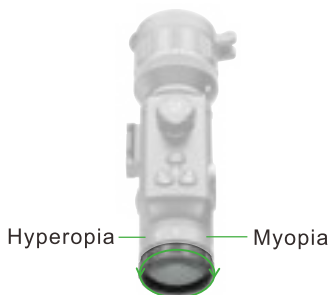

Rotate clockwise to adjust myopia.

Rotate counterclockwise to adjust hyperopia .



NOTE

- The diopter adjustment solely aims to ensure clear visibility of icons on the screen. Achieving sharp image clarity requires proper focusing of the objective lens.

4.2 Eyecup Installation

A soft eyecup gives the eyes good cushioning and reduces interference from ambient light. To install the eyecup, rotate it clockwise into the eyepiece until it is securely tightened.

65mm eyecup



4.3 Objective Lens Installation and Removal

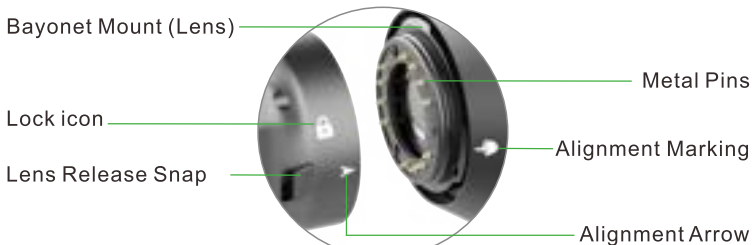

NOTE

- **After each lens change, please re-calibrate and set zero before use.**
- When replacing the lens, ensure it is done swiftly in an environment with minimal dust.
- Before installing the lens, please ensure that the bayonet mount on the body, lens, and the metal pins are clean and free of dust.
- When storing the device without a lens attached, attach the body cap to the device .
- After removing the lens from the NV500, place the rear end of the lens facing up and install the lens cap to prevent scratches on the lens surface and electronic contacts.
- Avoid applying excessive force when handling the lens to prevent damage.

When replacing the lens, please turn off the device.

(1) Lens Installation :

a. Remove the rear cover of the lens and the body cap.



- b. Locate the white alignment arrow positioned above the lens release catch. On the lens's rear end, you'll find a alignment marking on the round housing. Align the marking with the arrow on the device end.
- c. Insert the lens into the bayonet mount (Body) and rotate it clockwise until it locks.
- d. Once you hear a distinct 'click', the lens alignment dot aligns with the lock icon next to the lens release catch, the lens is securely installed.

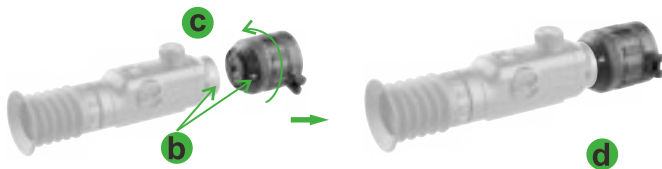

NOTE

- Please ensure the lens is installed successfully before releasing your grip on the lens.

(2) Lens Removal:

- Depress the lens release snap fully to the bottom and keep holding it.
- Rotate the lens in a clockwise direction.
- Hold and firmly press the NV500 lens until the Lens Release Snap on the NV500 body is pressed to the bottom. Rotate the lens towards the lock icon to lock it.

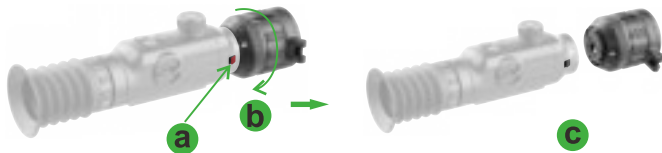

- After each lens change, please re-calibrate and set zero before use.

4.4 Lens Recognition

The system will automatically recognize the lens after loading different objective lenses.

Lens Recognition: On NV500, Commander 30mm lens displays , Commander 50mm lens displays , Commander 70mm lens displays . On NV500 eagle, Commander 30mm lens displays , Commander 50mm lens displays , Commander 70mm lens displays .  means no lens.

4.5 Objective Focusing

Rotate the focusing ring of the objective lens to ensure a clear display of objects observed at varying distances on the screen. Rotate clockwise to observe nearby objects and counterclockwise to observe distant objects.



4.6 Aperture adjustment

- The aperture controls the amount of light passing through the lens.
- Rotate the aperture ring counterclockwise to narrow the aperture, the aperture value becomes larger and the amount of incoming light becomes smaller so that the picture becomes darker and the depth of field increases, applicable to strong light when the picture is too bright.
- Rotate the aperture ring clockwise to widen the aperture, the aperture value becomes smaller and the amount of light becomes larger so that the picture becomes brighter, which can be used for daily use.



Widen aperture



Narrow aperture

4.7 Scope Mount Installation

There are 6 screw holes on the bottom of the device for mounting scope mount.

- Place the scope mount onto the mounting slots and adjust it forward or backward to a position for viewing.
- Align any four consecutive screw holes, place the screws into the screw holes
- Use a 5/32 inch wrench to tighten the 3 screws in turn.

If you use a power wrench to install the screws, it is recommended to use a torque of 13N.m

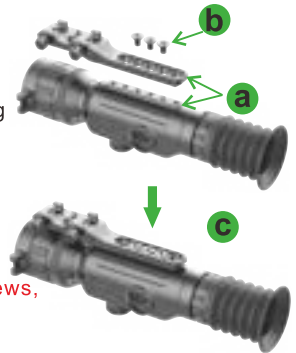

5. Rangefinder (Optional)

Measuring range: 5.5~1300yards

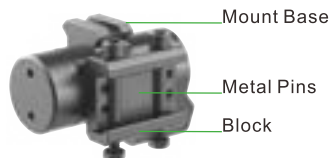
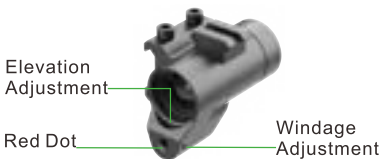

5.1 Installation

- Turn the nut counterclockwise to move the block down.
- Insert the Rangefinder into the NV500 side groove.
- Tighten the 2 nuts on the rangefinder clockwise with a wrench to make sure they are securely fastened.

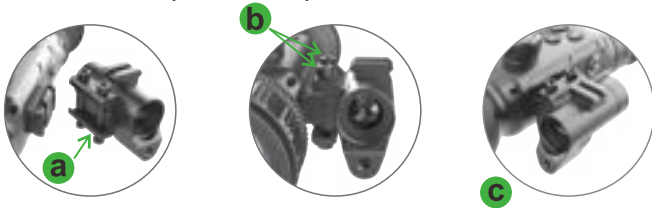

5.2 Operation

- In Home Screen, short press  vertically to turn on/off rangefinder function, the icons  and  appear on the screen.

If the system detects that no external rangefinder is installed or the target currently measured by the rangefinder is out of range, the red icon will turn gray .

- Please switch to black and white mode and align the rangefinder cursor and blinking piont (Refer to the MENU 'Range Marker Align')



6.Illuminator

6.1 Product Image

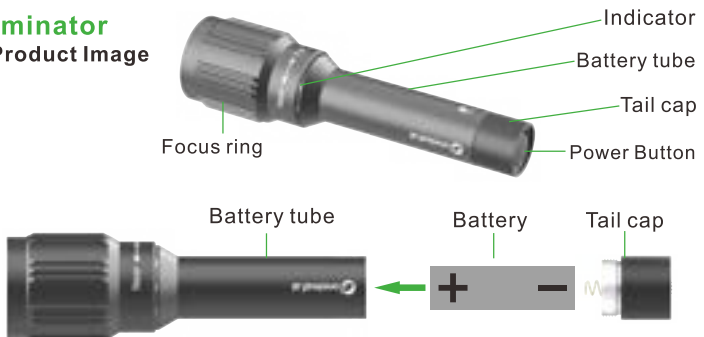

! Please hold the battery tube(not the illuminator focus ring)when tightening/loosening the tail-cap.

- **Focus ring** : Rotate it clockwise to focus the illuminator for observing objects at a distance. Rotate it counterclockwise to dispense the illuminator for observing objects at a short range.

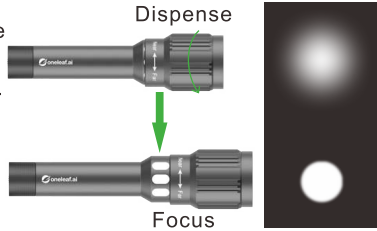

- **Indicator:**  Level 1/  Level 2/  Level 3. 1st Gear - 50% Brightness; 2nd Gear - 75% Brightness; 3rd Gear - 100% Brightness.

- **Power button:**

Tap the power button to cyclically switch brightness level.

Short press the power button to toggle the illuminator on or off. The illuminator includes a memory function that automatically switches to the next brightness level each time it is turned on, based on the previous setting.

- **Tail cap:** Remove the tail cap, insert the battery into the battery tube with the positive terminal facing inward, and finally tighten the tail cap.

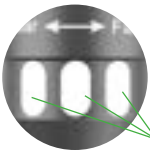

The indicator light and LED flashes when the battery runs out. Please replace battery.

NOTE

- After replacing the battery, the illuminator will automatically turn on. Please ensure to turn it off if it is not in use.
- If you won't use the illuminator for a long time, remove the battery.

6.2 Illuminator Mounting

(1) Mount into the left-side grooves of the NV500

Install the illuminator onto its mount:

- a. Loosen the fixing nut.
- b. Place the illuminator into the fixing ring of the mount.
- c. Tighten the fixing nut.

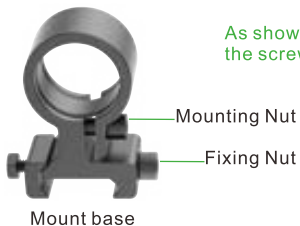

As shown in the picture,
the screw head faces upwards.

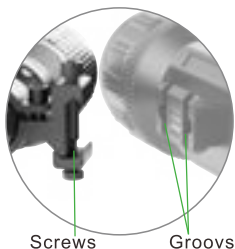
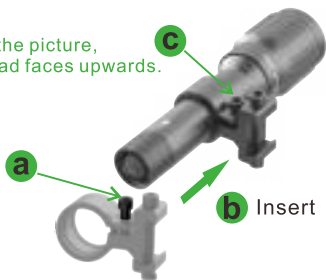

The screw head faces upwards for easy tightening.



(2) Mount into the top mount base of the rangefinder and tighten the mounting nut.

As shown in the picture,
the screw head faces outwards.

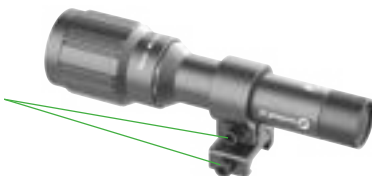





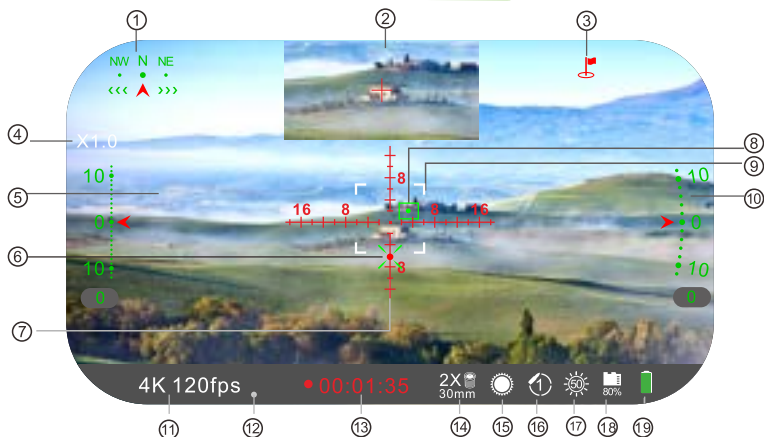

As shown in the picture,
the screw head faces outwards for easy tightening.

NOTE

- Prolonged operation of the illuminator may cause the metal housing to become too hot, so be careful of burns.
- Turn off the illuminator when not in use.
- Make sure the illuminator lens is clean before each use.





HOME SCREEN



- ① **E-Compass:** Showing yaw angle based on e-Magnetometer data.
- ② **Picture-in-Picture:** Partial zoom in.
- ③ **Rangefinder:** Short press  to turn on the rangefinder function and a red flag icon  will appear on the screen. If the system detects that there is no external rangefinder installed or the target measured by the current rangefinder is out of range, the icon will turn gray . When viewing the recorded video on a computer, the ranging data will be displayed at the top right of the video.
- ④ **Digital Zoom:** Default x1.0, maximum x8.0. Rotate  clockwise to zoom in and counterclockwise to zoom out. The digital zoom icon will be displayed at the right of the video when viewing the recorded video on a computer.
- ⑤ **Gyroscope Pitch Angle:** Shows inclination based on internal 3D Gyro.
- ⑥ **Ballistic Point of Impact:**  that is adjusted according to the reticle and ballistic parameters when the Ballistic Parameters is turned on.
- ⑦ **Reticle:** Used for aiming reference.
- ⑧ **Rangefinder Cursor:** It indicates the position of to the blinking point for ranging. Aim the cursor at the object to be measured and the distance reading will be displayed in the upper right corner of the Rangefinder Cursor. If the position of the blinking point is shifted, you can easily realign the cursor via the menu settings to overlap with the new blinking point.

- ⑨ **Capture Icon:** Long press  to take a picture. The icon will appear on the screen and disappear once the shooting is complete.
- ⑩ **Gyroscope Roll Angle:** Shows device cant based on internal 3D Gyro.
- ⑪ **Video Resolution:** Displays the recording resolution of the currently selected video. It can be set 4K 30fps/4K60fps/4K120fps.
- ⑫ **Status bar:** It can be set in the Menu to show all the time or hide when there is no operation (default).
- ⑬ **Recording Time:** Short press  to start recording. The recording time will increase as the recording progresses. Short press  again to pause recording, and the recording time icon will vanish. Users can customize the auto-save duration to 2min/ 3min/ 5min or 10 min through the Menu settings.
- ⑭ **Lens Recognition:** On NV500, Commander 30mm lens displays , Commander 50mm lens displays , Commander 70mm lens displays . On NV500 eagle, Commander 30mm lens displays , Commander 50mm lens displays , Commander 70mm lens displays .  means no lens.
- ⑮ **Mode:** Short press  to toggle between Day  /Starry  /Night . When you switch mode from Day to Starry, you'll hear a 'tick' sound; When you switch mode from Starry to Night, you won't hear a 'tick'; When you switch mode from Night to Day, you'll hear a 'tick'.
- ⑯ **Position:** The serial number inside the icon represents the Position's group number. There are 6 Position profiles in total. Each Position has three attributes: Reticle Type, Reticle Color, and Shot Zero.
- ⑰ **LCD Brightness:** Short press  to adjust the LCD brightness. Each short press decreases the brightness by 10%. When the brightness reaches 0%, a subsequent short press will set the brightness to 100.
- ⑱ **Micro SD Card:**  Shows Micro SD card is inserted.  shows no Micro SD card is inserted. The percentage indicates the available space on the card.
- ⑲ **Battery:** There are 5 levels     . Each representing 20% of the charge. The icon will cycle through in an incremental pattern while charging.



MENU

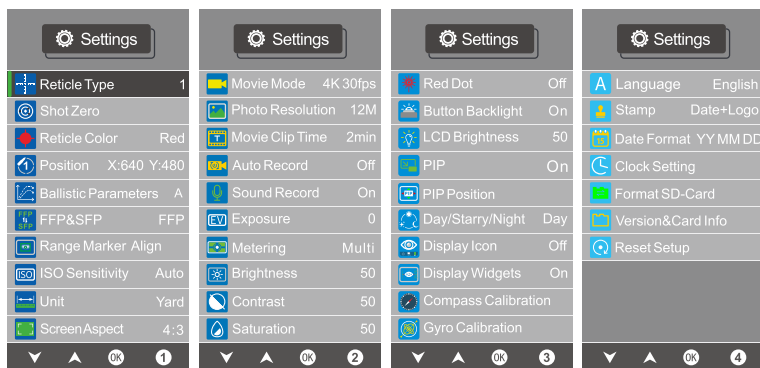

- Long press  vertically on the Home Screen to enter MENU.
- Rotate  to move up and down. Short press  to go to previous MENU and short press  to go to next MENU.
- In MENU, long press  vertically to exit MENU.

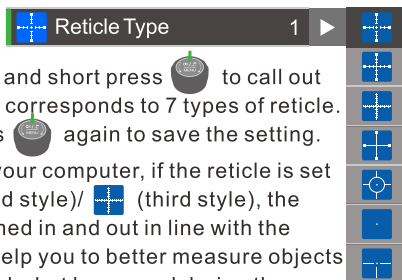

Reticle Type





Rotate  to select 'Reticle Type' and short press  to call out 7 types. The number 1/2/3/4/5/6/7 corresponds to 7 types of reticle. Select a style and then short press  again to save the setting.

When viewing playback video on your computer, if the reticle is set to the  (first style)/  (second style)/  (third style), the reticle in the playback will be zoomed in and out in line with the reticle in the recording. This will help you to better measure objects based on the crosshairs and record what happened during the recording of the video.

Shot Zero



Rotate  to move the cursor to select Shot Zero, press  to enter the adjustment interface to adjust the position of the reticles.

- Short press  to switch to X or Y, the selected coordinate and value will be shown in blue color.

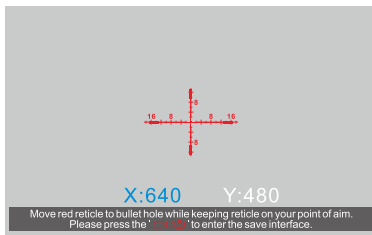

X Value is selected

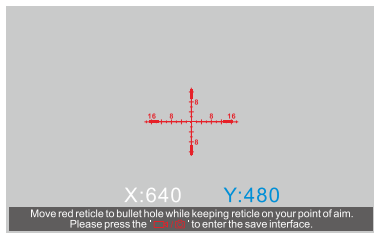

Y Value is selected

(1) When **X** value is selected (**X** value shown in blue color)

Rotating  counterclockwise, the **X** value decreases and the red reticle move to the left.

Rotating  clockwise, the **X** value increases and the red reticle move to the right (the reticle is the starting position)

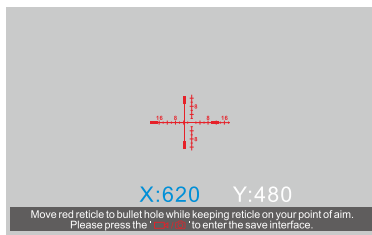

Rotating the knob counterclockwise, the X value decreases.



Rotating the knob clockwise, the X value increases.

(2) When **Y** value is selected (**Y** value shown in blue color)

Rotating  counterclockwise, the **Y** value decreases and the red reticle move to the left.

Rotating  clockwise, the **Y** value increases and the red reticle move to the right (the reticle is the starting position)

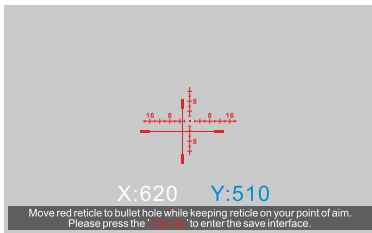

Rotating the knob counterclockwise, the X value decreases.

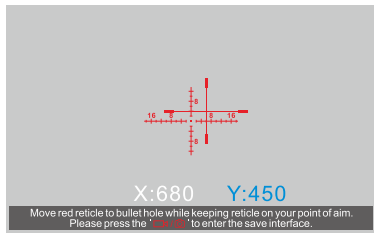

Rotating the knob clockwise, the X value increases.

If there is no need to set the group, Long press the [OK] to save is saved by default in Group 1 [1].

- Short press recording button [OK] to call out the position options.

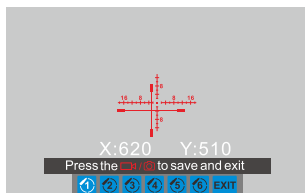

Position Group of Options

- Rotate [OK] to select to save the data into position 1-6 (the selected position will turn white), short press [OK] to confirm the selection. After position is saved successfully, device automatically return to the menu interface.

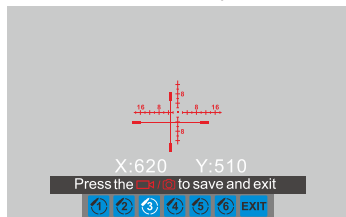

Position 3 is selected

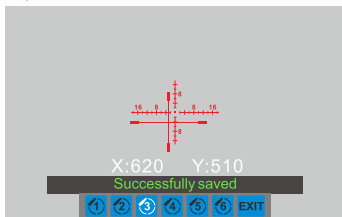

Successfully saved

- Select **EXIT**, short press [OK] to confirm the selection, the position save failed and automatically return to the menu interface.

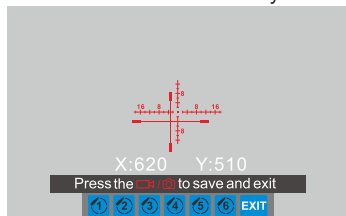



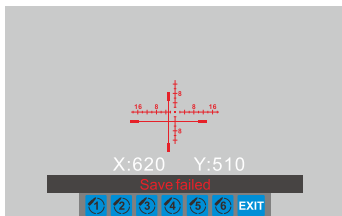

Position 3 is selected

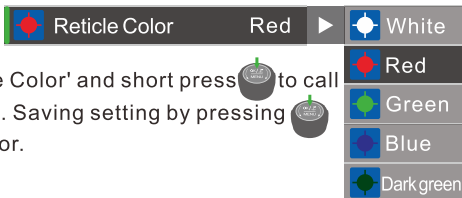

Save failed

Reticle Color



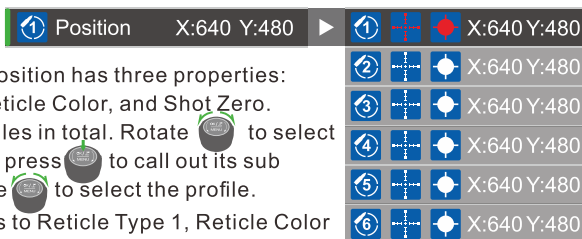

Rotate  to select 'Reticle Color' and short press  to call out 5 options (Default Red). Saving setting by pressing  again after you select a color.

Position



Each group of Position has three properties: Reticle Type, Reticle Color, and Shot Zero.

There are 6 profiles in total. Rotate  to select 'Position', short press  to call out its sub menu, and rotate  to select the profile.

Profile 1 defaults to Reticle Type 1, Reticle Color Red, X: 640, Y: 480; Other Profiles default to Reticle Type 1, Reticle Color White, X: 640, Y: 480.

Ballistic Parameters



The Ballistic Parameters allows you to quickly calculate the trajectory of a bullet and give you the exact point of impact.







NOTE

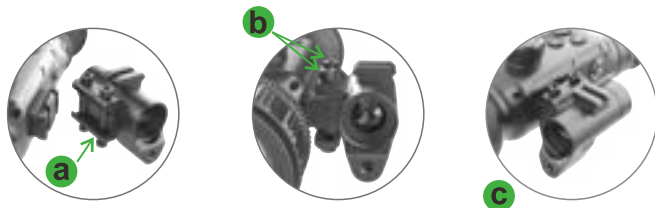

- To enable this feature, the device must have a rangefinder installed and have the rangefinder function turned on.**
- When the unit in the menu is set to Yard, all units in the ballistic parameter are switched to imperial; When the unit in the menu is set to Meter, all units in the ballistic parameters are switched to metric.**
- To ensure the accuracy of the parameters, please make sure that the units in the ballistic parameters are the same as the actual measurement units.**





(1) Install the rangefinder to Commander NV500.

- a. Turn the nut counterclockwise to move the block down.
- b. Insert the Rangefinder into the NV500 side groove.
- c. Tighten the 2 nuts on the rangefinder clockwise with a wrench to make sure they are securely fastened.

















(2) Long Press  to enter MENU, rotate  to select  Ballistic Parameters A

Short press  to call out submenu for parameter setting. Long press  to return to MENU.





Settings	
	Reticle Type 1
	Shot Zero
	Reticle Color Red
	Position X:640 Y:480
	Ballistic Parameters A
	FFP&SFP FFP
	Range Marker Align
	Unit Yard
	ISO Sensitivity Auto
	Screen Aspect 4:3

MENU

	Ballistic Switch	On
	Ballistic Group	A
	Ballistic Coefficient	0.029
	Ballistic Model	G1
	Bullet Weight(gr)	15.59
	Initial Velocity(ft/s)	900
	Zero Range(yd)	20
	Sight Height(Inches)	2.00
	Shooting Angle(deg)	1
	Wind Velocity(mph)	0.1
	Wind Angle(deg)	1
	Altitude(ft)	1643
	Temperature(F)	59
	Barometric Pressure(in Hg)	29.9
	Relative Humidity(%)	75.0

SUBMENU

(3) After setting the parameters, long press  to save the settings and return to the main menu.

(4) In the Home Screen, a short press  turns on both the rangefinder and ballistic functions, and  will be displayed on the screen. Aim the rangefinder cursor at the target and  will move according to the ballistic parameters and actual distance. After determining the target position, short press  to lock  and turn off the rangefinder function.



Rangefinder cursor aligns to the target

(5) Align  with the point of aim.

















Align  with the point of aim.

Rotate  to select Ballistic Parameters and short press  to enter Ballistic Parameters setting.















Unit: Yard
Ballistic Parameters are in imperial unit.





 Ballistic Switch	On	
 Ballistic Group	A	
 Ballistic Coefficient	0.029	
 Ballistic Model	G1	
 Bullet Weight(gr)	15.59	Unit: Grain
 Initial Velocity(ft/s)	900	Unit: ft/s
 Zero Range(yd)	20	Unit: yard
 Sight Height(inches)	2.00	Unit: Inches
 Shooting Angle(deg)	1	Unit: deg
 Wind Velocity(mph)	0.1	Unit: mph
 Wind Angle(deg)	1	Unit: deg
 Altitude(ft)	1643	Unit: ft
 Temperature (F)	59	Unit: F
 Barometric Pressure(in hg)	29.9	Unit: in Hg
 Relative Humidity(%)	75.0	

Unit: Meter
Ballistic Parameters are in Metric unit.









 Ballistic Switch	On	
 Ballistic Group	A	
 Ballistic Coefficient	0.029	
 Ballistic Model	G1	
 Bullet Weight(g)	1.010	Unit: g
 Initial Velocity(m/s)	274.32	Unit: m/s
 Zero Range(m)	18.29	Unit: m
 Sight Height(cm)	5.08	Unit: cm
 Shooting Angle(deg)	1	Unit: deg
 Wind Velocity(mph)	0.045	Unit: m/s
 Wind Angle(deg)	1	Unit: deg
 Altitude(m)	500.79	Unit: m
 Temperature (C)	15.00	Unit: C
 Barometric Pressure(hPa)	1012.53	Unit: hPa
 Relative Humidity(%)	75.0	















These parameters determine  trajectory and accuracy. When using NV500, please adjust these parameters according to your actual situation and needs to get the best performance.

If your  is beyond the reasonable range set by the system, the system will prompt .



In the submenu of Ballistic Parameters, rotate  to select 'Ballistic Switch'. Short press  to call out two options: On/Off. Rotate  to select the option and short press  to save the setting.

For rangefinder-equipped devices, when Ballistic Switch is on, short press  in the Home Screen, ballistic function and rangefinder function will be turned on at the same time; when Ballistic Switch is off, short press  in the main interface, only the rangefinder function will be turned on, the ballistic function will not be activated and  will not appear.

ON/OFF	Ballistic Switch	On
	Ballistic Group	A
	Ballistic Coefficient	0.029
	Ballistic Model	G1
	Bullet Weight(gr)	15.59
	Initial Velocity(ft/s)	900
	Zero Range(yd)	20
	Sight Height(inches)	2.00
	Shooting Angle(deg)	1
	Wind Velocity(mph)	0.1
	Wind Angle(deg)	1
	Altitude(ft)	1643
	Temperature (F)	59
	Barometric Pressure(in hg)	29.9
	Relative Humidity(%)	75.0

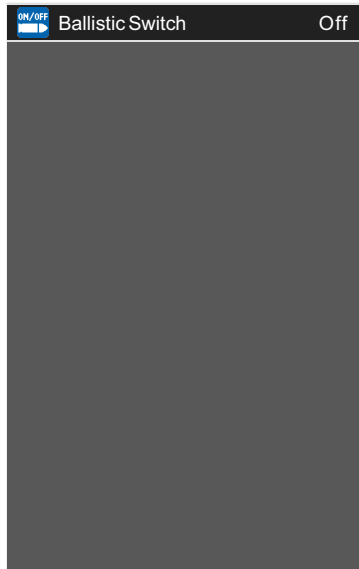

When Ballistic Switch is turned **ON**.



When Ballistic Switch is turned **OFF**.





	Ballistic Group	A	▶	A
				B
				C
				D
				E
				F
				G







In the submenu of Ballistic Parameters, rotate  to select 'Ballistic Group'. Short press  to call out 7 options(A/B/C/D/E/F/G), the default value is group A. Ballistic Group can be used to save 7 groups of ballistic data under different environments.

















Ballistic Coefficient

0.029

In the submenu of Ballistic Parameters, rotate  to select 'Ballistic Switch'. Short press  to call out two options: ON/OFF. After selecting the option, short press  again to save the setting. The Ballistic Switch is 'On' by default.



In the submenu of Ballistic Parameters, rotate  to select 'Ballistic Coefficient' and short press  to enter its setting. Rotate  clockwise to increase the value by 0.001, and rotate  counterclockwise to decrease the value by 0.001. You can also increase the value by 0.01 by pressing , and decrease the value by 0.01 by pressing . Short press  to confirm the setting after adjusting the value.

 Ballistic Switch	On	
 Ballistic Group	A	
 Ballistic Coefficient	0.029	▶ ◀ 0.029 ▶
 Ballistic Model	G1	
 Bullet Weight(gr)	15.59	
 Initial Velocity(ft/s)	900	
 Zero Range(yd)	20	
 Sight Height(Inches)	2.00	
 Shooting Angle(deg)	1	
 Wind Velocity(mph)	0.1	
 Wind Angle(deg)	1	
 Altitude(ft)	1643	
 Temperature(F)	59	
 Barometric Pressure(in Hg)	29.9	
 Relative Humidity(%)	75.0	

Ballistic Coefficient

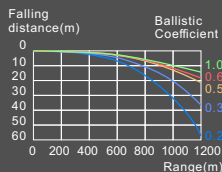
The indicator of a bullet's ability to overcome air resistance in flight. The ballistic coefficient of a bullet can be found on the bullet package box, the manufacturer's website, or searching the Internet.







Rotate  clockwise or counterclockwise to increase or decrease value. Press  button to decrease and press  to increase value.

















The ballistic model is a numerical model used to calculate ballistic trajectories.

Depending on the ballistic model, it is possible to predict the flight path, point of impact, and the shooting accuracy of the bullet.

It can be found in the product package box, the manufacturer's website, or the internet. If you are unsure, you can use the default option G1.



In the submenu of Ballistic Parameters, rotate  to select 'Ballistic Model'. Short press  to call out 7 options: G0/G1/G2/G5/G6/G7/G8. G1 is the default option. Rotate  to select any option and short press  to save the setting.

 Ballistic Switch	On		
 Ballistic Group	A		
 Ballistic Coefficient	0.029		
 Ballistic Model	G1	▶	G0
 Bullet Weight(gr)	15.59		G1
 Initial Velocity(ft/s)	900		G2
 Zero Range(yd)	20		G5
 Sight Height(Inches)	2.00		G6
 Shooting Angle(deg)	1		G7
 Wind Velocity(mph)	0.1		G8
 Wind Angle(deg)	1		
 Altitude(ft)	1643		
 Temperature(F)	59		
 Barometric Pressure(in Hg)	29.9		
 Relative Humidity(%)	75.0		

Ballistic Model

It can be found at the product package box, the manufacturer's website, or searching the internet; if you are unsure, use G1.





Rotate  to select any of the options and short press  to save setting.





















The weight of the bullet affects the kinetic energy of the bullet at range.

It can be found on the package box or the cartridge case. If you are unsure, use a scale to measure it and be careful not to make a mistake with the units on the scale.

In the submenu of Ballistic Parameters, rotate  to select 'Bullet Weight' and short press  to enter its setting. The unit is Grains in the imperial system and g in the metric system.

When the unit is grains, rotate  clockwise to increase 0.01 grain and rotate  counterclockwise to decrease 0.01 grain; short press  to increase 1 grain and short press  to decrease 1 grain.



When the unit is g, allow the value deviation within plus or minus 0.01 g. Rotate  clockwise to increase the value and rotate  counterclockwise to decrease the value; Short press  to increase the value faster and short press  to decrease the value faster. Short press  to confirm the setting after adjusting the value.

	Ballistic Switch	On
	Ballistic Group	A
	Ballistic Coefficient	0.029
	Ballistic Model	G1
	Bullet Weight(gr)	15.59 ▶ ◀ 15.59 ▶
	Initial Velocity(ft/s)	900
	Zero Range(yd)	20
	Sight Height(Inches)	2.00
	Shooting Angle(deg)	1
	Wind Velocity(mph)	0.1
	Wind Angle(deg)	1
	Altitude(ft)	1643
	Temperature(F)	59
	Barometric Pressure(in Hg)	29.9
	Relative Humidity(%)	75.0

Bullet Weight

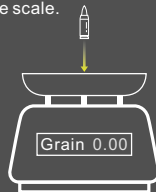
The weight of the bullet can be found on the package box, or on the cartridge case, if you are unsure, use an scale to measure its weight, and be careful not to make a mistake with the units on the scale.









Rotate  clockwise to increase or counterclockwise to decrease value. Press  button to decrease and press  to increase value.























This refers to the muzzle velocity in the trajectory, i.e. the speed of the bullet after it leaves the barrel.

Please use a timer to calculate the speed of the bullet leaving the barrel, or you can refer to the data provided by the bullet manufacturer.

In the submenu of Ballistic Parameters, rotate  to select 'Initial Velocity' and short press  to enter its setting. The imperial unit is ft/s, and the metric unit is m/s.

When the unit is ft/s, rotate  clockwise to increase 1 ft/s and rotate  counterclockwise to decrease 1 ft/s. Short press  to increase 100 ft/s and short press  to decrease 100 ft/s.



When the unit is m/s, the allowable deviation is within plus or minus 0.7 m/s. Rotate  clockwise to increase value and rotate  counterclockwise to decrease value. Short press  to increase the value faster, and short press  to decrease the value faster. Short press  to confirm the setting after adjusting the value.

	Ballistic Switch	On
	Ballistic Group	A
	Ballistic Coefficient	0.029
	Ballistic Model	G1
	Bullet Weight(gr)	15.59
	Initial Velocity(ft/s)	900
	Zero Range(yd)	20
	Sight Height(Inches)	2.00
	Shooting Angle(deg)	1
	Wind Velocity(mph)	0.1
	Wind Angle(deg)	1
	Altitude(ft)	1643
	Temperature(F)	59
	Barometric Pressure(in Hg)	29.9
	Relative Humidity(%)	75.0

Initial Velocity

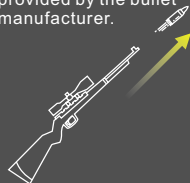

This refers to the muzzle velocity in the trajectory, i.e. the speed of the bullet after it leaves the barrel. Please use a timer to calculate the speed of the bullet leaving the barrel, or you can refer to the data provided by the bullet manufacturer.











Rotate  clockwise to increase or counterclockwise to decrease value. Press  button to decrease and press  to increase value.













It indicates the distance between the bullet and the zeroing point.

In the submenu of Ballistic Parameters, rotate  to select 'Zero Range' and short press  to enter its setting. The imperial unit is Yard, and the metric unit is M.

When the unit is Yard, rotate  clockwise to increase by 1 yd and rotate  counterclockwise to decrease by 1 yd. Short press  to increase by 10 yards, and short press  to decrease by 10 yards.



When the unit is M, the allowable deviation is within plus or minus 0.7 m. Rotate  clockwise to increase value and rotate  counterclockwise to decrease value. Short press  to increase the value faster and short press  to decrease the value faster. Short press  to confirm the setting after adjusting the value.

	Ballistic Switch	On	
	Ballistic Group	A	
	Ballistic Coefficient	0.029	
	Ballistic Model	G1	
	Bullet Weight(gr)	15.59	
	Initial Velocity(ft/s)	900	
	Zero Range(yd)	20	▶ ◀ 20 ▶
	Sight Height(Inches)	2.00	
	Shooting Angle(deg)	1	
	Wind Velocity(mph)	0.1	
	Wind Angle(deg)	1	
	Altitude(ft)	1643	
	Temperature(F)	59	
	Barometric Pressure(in Hg)	29.9	
	Relative Humidity(%)	75.0	

Zero Range

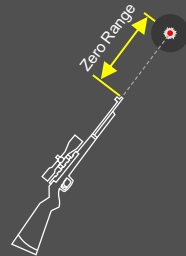
Indicates the distance between the bullet and the zeroing point.



Rotate  clockwise or counterclockwise to increase or decrease value. Press  button to decrease and press  to increase value.



It refers to the distance between the center of the scope optic and the center of the barrel. Please use a ruler to measure it.

In the submenu of Ballistic Parameters, rotate to select 'Sight Height' and short press to enter its setting. The imperial unit is Inches, and the metric unit is cm.

When the unit is Inches, rotate clockwise to increase by 0.01 inch and rotate counterclockwise to decrease by 0.01 inch. Short press to increase by 1 inch, and short press to decrease by 1 inch.

When the unit is cm, the allowable deviation is within plus or minus 0.1 cm. Rotate clockwise to increase value and rotate counterclockwise to decrease value. Short press to increase the value faster, and short press to decrease the value faster. Short press to confirm the setting after adjusting the value.

	Ballistic Switch	On
	Ballistic Group	A
	Ballistic Coefficient	0.029
	Ballistic Model	G1
	Bullet Weight(gr)	15.59
	Initial Velocity(ft/s)	900
	Zero Range(yd)	20
	Sight Height(Inches)	2.00
	Shooting Angle(deg)	1
	Wind Velocity(mph)	0.1
	Wind Angle(deg)	1
	Altitude(ft)	1643
	Temperature(F)	59
	Barometric Pressure(in Hg)	29.9
	Relative Humidity(%)	75.0

Sight Height

The distance between the center of the scope optic and the center of the barrel. Please measure with a scale.

Rotate clockwise or counterclockwise to increase or decrease value. Press button to decrease and press to increase value.



It represents the angle between the firearm and the ground when shooting.

In the submenu of Ballistic Parameters, rotate to select 'Shooting Angle' and short press to enter its setting. The unit is deg.

Rotate clockwise to increase by 1 deg and rotate counterclockwise to decrease by 1 deg. Short press to increase by 10 deg, and short press to decrease by 10 deg. Short press to confirm the setting after adjusting the value.

	Ballistic Switch	On
	Ballistic Group	A
	Ballistic Coefficient	0.029
	Ballistic Model	G1
	Bullet Weight(gr)	15.59
	Initial Velocity(ft/s)	900
	Zero Range(yd)	20
	Sight Height(Inches)	2.00
	Shooting Angle(deg)	1 1
	Wind Velocity(mph)	0.1
	Wind Angle(deg)	1
	Altitude(ft)	1643
	Temperature(F)	59
	Barometric Pressure(in Hg)	29.9
	Relative Humidity(%)	75.0

Shooting Angle

The angle the firearm forms with the ground when shooting.

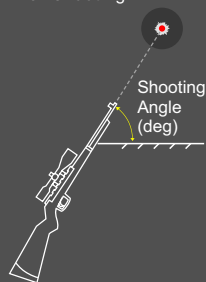

Rotate clockwise or counterclockwise to increase or decrease value. Press button to decrease and press to increase value.



The average wind Velocity of a bullet in flight. It can be measured with an anemometer or by referring to the data provided in the table.

Force	1	2	3	4	5	6	7	8
Velocity (mph)	1-3	4-7	8-12	13-18	19-24	25-31	32-38	39-46

In the submenu of Ballistic Parameters, rotate to select 'Wind Velocity' and short press to enter its setting. The imperial unit is mph and the metric unit is m/s.

When the unit is mph, rotate clockwise to increase by 0.1 mph and rotate counterclockwise to decrease by 0.1 mph. Short press to increase by 1 mph, and short press to decrease by 1 mph.

When the unit is m/s, the allowable deviation is within plus or minus 0.1 m/s. Rotate clockwise to increase value and rotate counterclockwise to decrease value. Short press to increase the value faster, and short press to decrease the value faster. Short press to confirm the setting after adjusting the value.

Ballistic Switch	On
Ballistic Group	A
Ballistic Coefficient	0.029
Ballistic Model	G1
Bullet Weight(gr)	15.59
Initial Velocity(ft/s)	900
Zero Range(yd)	20
Sight Height(Inches)	2.00
Shooting Angle(deg)	1
Wind Velocity(mph)	0.1
Wind Angle(deg)	1
Altitude(ft)	1643
Temperature(F)	59
Barometric Pressure(in Hg)	29.9
Relative Humidity(%)	75.0

Wind Velocity

The average wind Velocity during the flight of the bullet. This can be measured using an anemometer, or you can refer to the data provided in the table above.

Force	Symbol	Velocity (mph)
1		1-3
2		4-7
3		8-12
4		13-18
5		19-24
6		25-31
7		32-38
8		39-46

Rotate clockwise or counterclockwise to increase or decrease value. Press button to decrease and press to increase value.



The direction of the wind blowing towards the bullet path.

0° wind angle means that the wind is blowing toward the shooter's face.

90° wind angle means the wind is blowing to the shooter's right.

180° wind angle means the wind is blowing toward the rear of the shooter.

270° wind angle means the wind is blowing to the shooter's left.



In the submenu of Ballistic Parameters, rotate to select 'Wind Angle' and short press to enter its setting. The unit is deg. Rotate clockwise to increase value by 1 deg and rotate counterclockwise to decrease value by 1 deg. Short press to increase by 10 deg, and short press to decrease by 10 deg. Short press to confirm the setting after adjusting the value.

	Ballistic Switch	On		<h3>Wind Angle</h3> <p>The direction of the wind blowing towards the bullet path.</p> <p>0° The wind is blowing toward the shooter's face.</p> <p>90° The wind is blowing to the shooter's right side.</p> <p>180° The wind is blowing toward the back of the shooter.</p> <p>270° The wind is blowing to the left side of the shooter.</p> <p>Rotate clockwise or counterclockwise to increase or decrease value. Press button to decrease and press to increase value.</p>
	Ballistic Group	A		
	Ballistic Coefficient	0.029		
	Ballistic Model	G1		
	Bullet Weight(gr)	15.59		
	Initial Velocity(ft/s)	900		
	Zero Range(yd)	20		
	Sight Height(Inches)	2.00		
	Shooting Angle(deg)	1		
	Wind Velocity(mph)	0.1		
	Wind Angle(deg)	1	▶ ◀ 1 ▶	
	Altitude(ft)	1643		
	Temperature(F)	59		
	Barometric Pressure(in Hg)	29.9		
	Relative Humidity(%)	75.0		









Altitude(ft)





1643











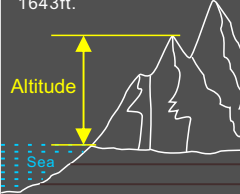







The height of the location from sea level. Different altitudes have different air densities, which affects the bullet trajectory.

If you don't know the altitude of your location, please use the default value of 1643 ft.

In the submenu of Ballistic Parameters, rotate  to select 'Altitude' and short press  to enter its setting. The Ft is the imperial unit and M is the metric unit.

When the unit is ft, rotate  clockwise to increase by 1 ft and rotate  counterclockwise to decrease by 1 ft. Short press  to increase by 100 ft, and short press  to decrease by 100 ft.

When the unit is m, the allowable deviation is within plus or minus 0.7 m. Rotate  clockwise to increase value and rotate  counterclockwise to decrease value. Short press  to increase the value faster, and short press  to decrease the value faster. Short press  to confirm the setting after adjusting the value.

	Ballistic Switch	On		<p>Altitude</p> <p>The height of the location from sea level. If you don't know the altitude of your location, use the default value of 1643ft.</p>  <p>Altitude</p> <p>Sea</p> <p>Rotate  clockwise or counterclockwise to increase or decrease value. Press  button to decrease and press  to increase value.</p>
	Ballistic Group	A		
	Ballistic Coefficient	0.029		
	Ballistic Model	G1		
	Bullet Weight(gr)	15.59		
	Initial Velocity(ft/s)	900		
	Zero Range(yd)	20		
	Sight Height(Inches)	2.00		
	Shooting Angle(deg)	1		
	Wind Velocity(mph)	0.1		
	Wind Angle(deg)	1		
	Altitude(ft)	1643	▶ ◀ 1643 ▶	
	Temperature(F)	59		
	Barometric Pressure(in Hg)	29.9		
	Relative Humidity(%)	75.0		



Temperature changes affect the velocity and air density of the bullet during flight.

If the temperature at the current position is unknown, use the default value of 59° F.

In the submenu of Ballistic Parameters, rotate to select 'Temperature' and short press to enter its setting. The units are ° F in imperial and ° C in metric.

When the unit is ° F, rotate clockwise to increase by 1° F and counterclockwise to decrease by 1° F. Short press to increase by 10° F, and short press to decrease by 10° F.

When the unit is ° C, the allowable deviation is within plus or minus 0.7° C. Rotate clockwise to increase value and rotate counterclockwise to decrease value. Short press to increase the value faster, and short press to decrease the value faster. Short press to confirm the setting after adjusting the value.

	Ballistic Switch	On		
	Ballistic Group	A		
	Ballistic Coefficient	0.029		
	Ballistic Model	G1		
	Bullet Weight(gr)	15.59		
	Initial Velocity(ft/s)	900		
	Zero Range(yd)	20		
	Sight Height(Inches)	2.00		
	Shooting Angle(deg)	1		
	Wind Velocity(mph)	0.1		
	Wind Angle(deg)	1		
	Altitude(ft)	1643		
	Temperature(F)	59		59
	Barometric Pressure(in Hg)	29.9		
	Relative Humidity(%)	75.0		

Temperature



The air and heat at a given time and place. If the temperature of the location is not known, use the default value of 59°F.

Rotate clockwise or counterclockwise to increase or decrease value. Press button to decrease and press to increase value.























The magnitude of the force acting perpendicular to the surface of an object in each unit area.

Barometric pressure varies not only with altitude but also with temperature. Changes in atmospheric pressure will affect the bullet's trajectory.

If the barometric pressure is unknown, use the default value of 29.9 inHg. In the submenu of Ballistic Parameters, rotate  to select 'Barometric Pressure' and short press  to enter its setting. Imperial units are inHg and metric units are hPa.

When the unit is inHg, rotate  clockwise to increase by 0.1 inHg and rotate  counterclockwise to decrease by 0.1 inHg. Short press  to increase by 1 inHg, and short press  to decrease by 1 inHg.



When the unit is hPa, the allowable deviation is within plus or minus 7 hPa. Rotate  clockwise to increase value and rotate  counterclockwise to decrease value. Short press  to increase the value faster, and short press  to decrease the value faster. Short press  to confirm the setting after adjusting the value.

	Ballistic Switch	On
	Ballistic Group	A
	Ballistic Coefficient	0.029
	Ballistic Model	G1
	Bullet Weight(gr)	15.59
	Initial Velocity(ft/s)	900
	Zero Range(yd)	20
	Sight Height(Inches)	2.00
	Shooting Angle(deg)	1
	Wind Velocity(mph)	0.1
	Wind Angle(deg)	1
	Altitude(ft)	1643
	Temperature(F)	59
	Barometric Pressure(in Hg)	29.9 ▶ ◀ 29.9 ▶
	Relative Humidity(%)	75.0

Barometric Pressure

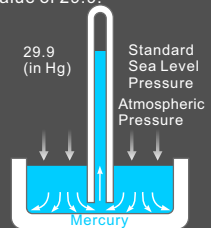

The magnitude of the force acting on each unit area in a direction perpendicular to the surface of an object. If the barometric is not known, use the default value of 29.9.





























Rotate  clockwise or counterclockwise to increase or decrease value. Press  button to decrease and press  to increase value.



Air humidity affects the air resistance and stability of bullets in flight.





In the submenu of Ballistic Parameters, rotate  to select 'Relative Humidity' and short press  to enter its setting. The unit of relative humidity is %.

Rotate  clockwise to increase by 0.1% and rotate  counterclockwise to decrease by 0.1%. Short press  to increase by 1%, and short press  to decrease by 1%. Short press  to confirm the setting after adjusting the value.

	Ballistic Switch	On	<h3>Relative Humidity</h3> <p>The ratio of the water vapor pressure in air at a given temperature to the saturated vapor pressure at the same temperature in percent.</p> <p>100%  Water Vapor Capacity</p> <p>50%  Water Vapor Capacity</p> <p>30%  Water Vapor Capacity</p> <p>Rotate  clockwise to increase or counterclockwise to decrease value. Press  button to decrease and press  to increase value.</p>
	Ballistic Group	A	
	Ballistic Coefficient	0.029	
	Ballistic Model	G1	
	Bullet Weight(gr)	15.59	
	Initial Velocity(ft/s)	900	
	Zero Range(yd)	20	
	Sight Height(Inches)	2.00	
	Shooting Angle(deg)	1	
	Wind Velocity(mph)	0.1	
	Wind Angle(deg)	1	
	Altitude(ft)	1643	
	Temperature(F)	59	
	Barometric Pressure(in Hg)	29.9	
	Relative Humidity(%)	75.0	

FFP&SFP









Rotate  to select 'FFP & SFP' and short press  to call out 2 options (FFP/SFP). When FFP is selected, the reticle's size will change with the magnification;
When SFP is selected, the reticle's size will not change with magnification.
Rotate  to select an option and short press  to save the setting.

Range Marker Align



Range Marker Align is only available on NV500 equipped with a rangefinder.

Rotate  to select 'Range Marker Align' and short press  to enter its setting. Short press  to switch to X or Y, the selected coordinate and value will change from white to red. Rotate  clockwise to increase the value and rotate  counterclockwise to decrease the value. After adjustment, long press  to save the setting.



Sub-interface

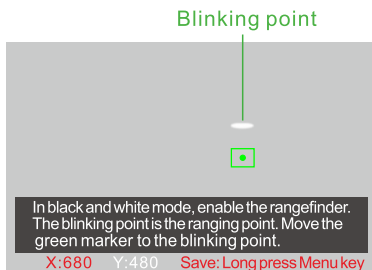

Value X adjustment

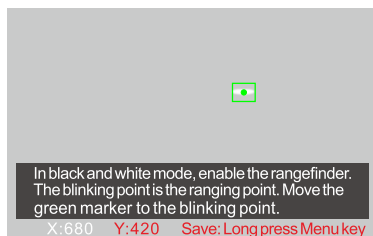





Value Y adjustment



Save





ISO Sensitivity

 ISO Sensitivity	Auto	▶	Auto
			ISO100
			ISO200
			ISO400
			ISO800
			ISO1600
			ISO3200

Rotate  to select 'ISO Sensitivity' and short press  to call out 7 options (Auto/ISO100/ISO200/ISO400/ISO800 /ISO1600/ISO3200). Rotate  to select the option and short press  to save the setting.





Unit

 Unit	Yard	▶	Yard
			Meter

Rotate  to select 'Unit' and short press  to call out 2 options (Yard/Meter). Rotate  to select an option and short press  to save setting.





Screen Aspect

 ScreenAspect	4:3	▶	4:3
			16:9
			Small

Rotate  to select 'Screen Aspect' and short press  to call out 3 options. Rotate  to select an option and short press  to save setting.

Movie Mode

 Movie Mode	4K 30fps	▶	4K 30fps
			4K 60fps
			4K 120fps

Rotate  to select 'Movie Mode' and short press  to call out 3 options (4K 30fps/4K 60fps/4K 120fps). Rotate  to select the option and press  to save the setting.







When 4K 30fps/4K 60fps/4K 120fps mode is selected to record video, the state of  during recording will be retained in the video.





Photo Resolution

 Photo Resolution	12M	▶	48M
			24M
			12M
			8M

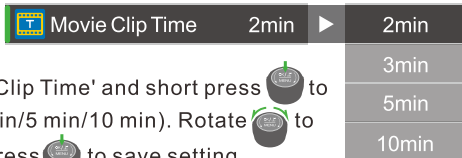
Rotate  to select 'Photo Resolution' and short press  to call out 4 options (48M/24M/12M/8M). Rotate  to select the option and short press  to save the setting.

Movie Clip Time





Rotate  to select 'Movie Clip Time' and short press  to call out 4 options (2 min/3 min/5 min/10 min). Rotate  to select an option and short press  to save setting.

Auto Record







Rotate  to select 'Auto Record' and short press  to call out the 2 options (On/Off).

If you turn on Auto Record, the machine will automatically turn on the recording after the next power on. Rotate  to select the option and short press  to save the setting.





Sound Record



Rotate  to select 'Sound Record' and short press  to call out the 2 options (On/Off). If Sound Record is on, the device will record a video with audio. Rotate  to select the option and short press  to save the setting.





Exposure

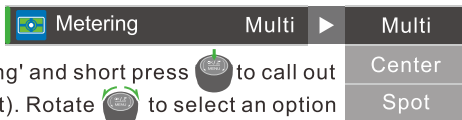

Rotate  to select 'Exposure' and short press  to call out setting bar. Rotate  to adjust value and short press  to save setting. Under different light conditions, adjust the exposure value can achieve best imaging.





Metering



Rotate  to select 'Metering' and short press  to call out 3 options (Multi/Center/Spot). Rotate  to select an option and short press  to save setting.

Brightness







Rotate  to select 'Brightness' and short press  to call out setting bar. Rotate  clockwise to increase the value by 5. Rotate  counterclockwise to decrease the value by 5. Short press  again to save setting.

Note: When the value is 50, the display automatically adjusts brightness according to the environment.

Contrast







Rotate  to select 'Contrast' and short press  to call out the setting bar. Rotate  clockwise to increase the value by 5. Rotate  counterclockwise to decrease the value by 5. Short press  to confirm the setting after adjusting the value.

Note: When the value is 50, the display will automatically adjust the contrast according to the environment.

Saturation



Rotate  to select 'Saturation' and short press  to call out the setting bar. Rotate  clockwise to increase the value by 5. Rotate  counterclockwise to decrease the value by 5. Short press  to confirm the setting after adjusting the value.

Note: When the value is 50, the display will automatically adjust the saturation according to the environment.





Red Dot

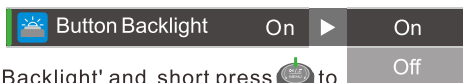

Range Marker Align is only available on NV500 equipped with a rangefinder.

Button Backlight









Rotate  to select 'Button Backlight' and short press  to call out 2 options (ON/OFF). Rotate  to select an option and short press  to save setting.

Shortcut: Press  and  simultaneously to turn on/off button backlight.

LCD Brightness





Rotate  to select 'LCD Brightness' and short press  to call out the setting bar. rotate  clockwise to increase the value by 5, rotate  counterclockwise to decrease the value by 5. Rotate  to select the option and short press  to save the setting.

Shortcut key: On the Home screen, short press  to adjust the LCD brightness quickly. Each short press will adjust 10 values.

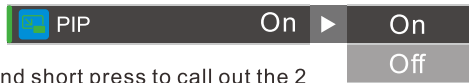
PIP









Rotate  to select 'PIP' and short press to call out the 2 options (PIP On/PIP Off). Rotate  to select the option and short press  to save the setting.

Shortcut key: On the Home screen, long press  to turn on/off PIP quickly.

PIP Position



Rotate  to select 'PIP Position' and short press  to enter its setting. Short press  to switch to X or Y, the selected coordinate and value will change from white to blue. Rotate  clockwise to increase the value and rotate  counterclockwise to decrease the value. After adjustment, long press  to save the setting.

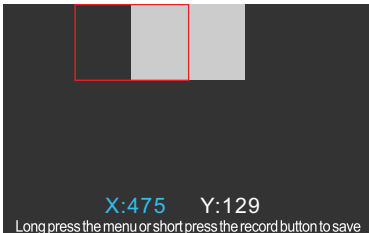



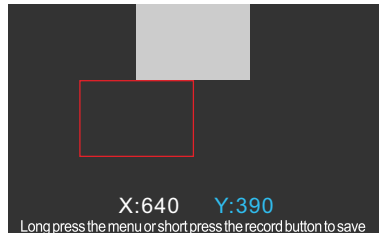

Value X adjustment



Value Y adjustment

Day/Starry/Night







Rotate  to select 'Day/Starry/Night' and short press  to call out 3 options (Day/Starry/Night). Rotate  to select an option and short press  to save setting.

Shortcut: Short press  in main interface to switch Day/Starry/Night.

Display Icon







Rotate  to select 'Display Icon' and short press  to call out 2 options (ON/OFF). Rotate  to select an option and short press  to save setting.

The default status is Off, and the status bar at the bottom of the Home screen will be hidden after 7 seconds of no operation. You can press any key to call out the status bar. When On is selected, the status bar will be displayed all the time.

Display Widgets





Rotate  to select 'Display Widgets' and short press  to call out 2 options (ON/OFF). Rotate  to select an option and short press  to save setting.

The system default status is On, and the real-time data of the gyroscope and E-Compass will be displayed on the Home screen; when Off is selected, the Home screen will not display the gyroscope and E-Compass data.

Compass Calibration



Rotate  to select 'Compass Calibration', short press  to enter the Compass Calibration operation page, and follow the animation to draw the letter 'O' 14-20 times for calibration. Please follow the prompts until the screen indicates calibration success or failure. Short press  to exit Compass Calibration.

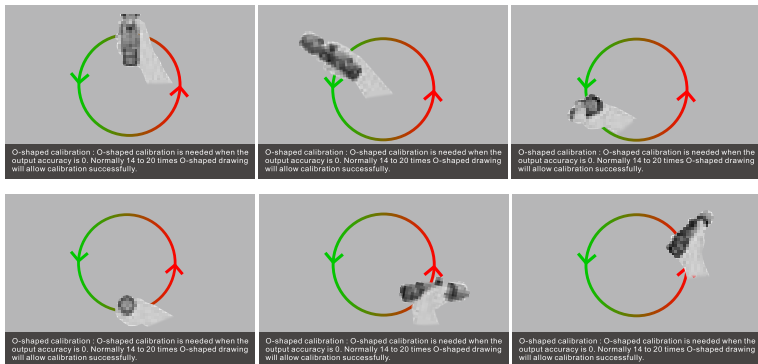

Sub-interface

O-shaped calibration : O-shaped calibration is needed when the output accuracy is 0. Normally 14 to 20 times O-shaped drawing will allow calibration successfully.



Calibration Successfully

Calibration successful.
Press and hold the menu button to exit.





Calibration Failed

Calibration failed.
Press and hold the menu button to exit

Gyro Calibration



Rotate  to select 'Gyro Calibration' and short press  to enter the Gyro Calibration operation page. Follow the prompts and the screen will indicate the calibration success or failure after 15 to 20 seconds of horizontal placement. Short press  to exit Gyro Calibration.

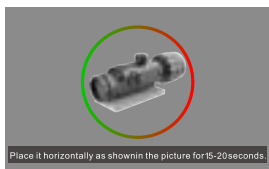

Sub-interface

Place it horizontally as shown in the picture for 15-20seconds.



Calibration Successfully

Calibration successful. Press and hold the menu button to exit.







Calibration Failed

Calibration failed. Press and hold the menu button to exit.





Language



Rotate  to select 'Language' and short press  to call out options. Rotate  to select an option and short press  to save setting.





Stamp

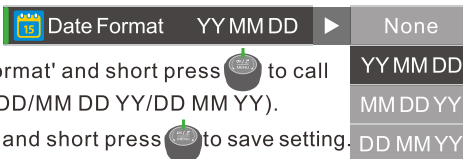

Rotate  to select 'Stamp' and short press  to call out 4 options (Date+Logo/Date/Logo/Off). Rotate  to select an option and short press  to save setting.







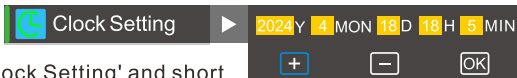

Date Format



Rotate  to select 'Date Format' and short press  to call out 4 options (None/YY MM DD/MM DD YY/DD MM YY). Rotate  to select an option and short press  to save setting.





Clock Setting

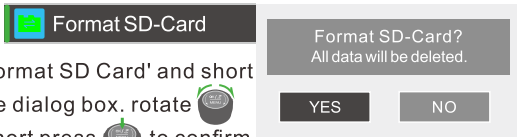

Rotate  to select 'Clock Setting' and short press  to enter setting. Rotate  to select  /  /  , short press  to increase or decrease value, short press  to save setting. You can set Year/Month/Date/Hour/Minute sequentially. Short press  when you complete the clock setting.

Format SD-Card





Rotate  to select 'Format SD Card' and short press  to call out the dialog box. rotate  to select YES or NO, short press  to confirm.

When YES is selected, all the data in the SD-card will be formatted, and "Format Complete" will be prompted when the formatting is successful; when NO is selected, it will return to the main menu.

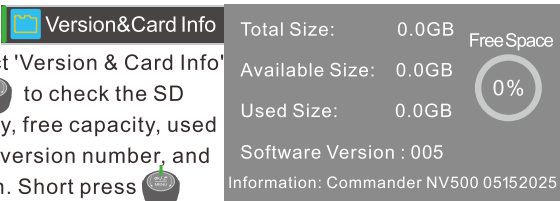



Version&Card Info

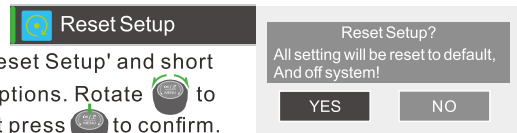

Rotate  to select 'Version & Card Info' and short press  to check the SD card's total capacity, free capacity, used capacity, system's version number, and version information. Short press  to return to the menu.

Reset Setup









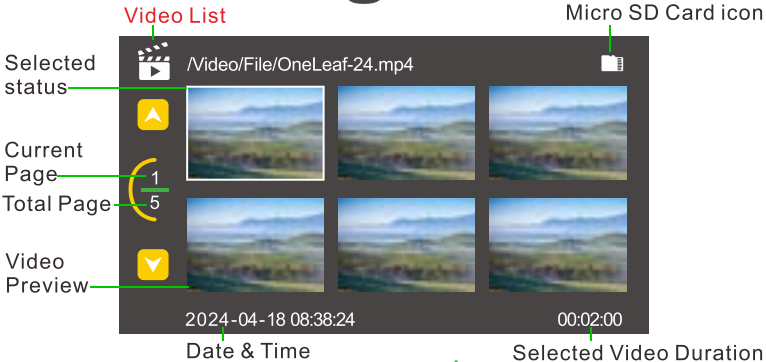

Rotate  to select 'Reset Setup' and short press  to call out 2 options. Rotate  to select YES or No ,short press  to confirm. If YES is selected, all setting will be reset to default.

Note: The device will be turned off after reset.

PLAYBACK

Video Playback: Press and hold  button to enter Video list.



- Rotate  to select a video. Short press  to play the video, short press  to pause play. Rotate clockwise or counter clockwise to switch to previous video or next video. Short press  to return to the video playback list.
-  shows Micro SD card inserted,  shows no Micro SD card is inserted. **No file** shows No File.
- If a file is renamed on the computer, it will disappear in the playback list.
- In video playback list, press and hold  to enter playback setting.

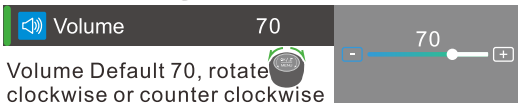
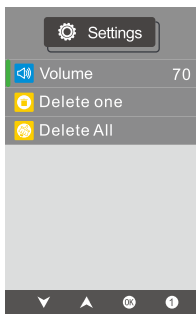

Volume Default 70, rotate  clockwise or counter clockwise to increase or decrease value.



Delete One
Choose YES to delete a selected file.

Delete Selected File?



YES NO



Delete All
Choose YES to delete all files.

Delete all files?

YES NO

- Long press  to exit playback setting.
- On the video playback page, short press  again to return to the main menu.

FIRMWARE UPDATE

1. Visit the official website: www.oneleaf.ai

2. Go to 'Download' and find the correct firmware.

3. Download the latest firmware file and put it into the root directory of the Micro SD card.

4. Insert the Micro SD card into the device.

5. Make sure the device has enough power, long press  to turn on the device.

6. The screen will light up and the system will be upgraded automatically.

7. The device will enter the home screen after the firmware upgrade is done.

8. Press  to enter the menu page, and select 'Format SD-Card'.

9. Check whether the version number is upgraded to the corresponding version and reset the system.



Updating





Updated

NOTE

- Please format the Micro SD card on the device before the firmware upgrade.
- Please do not power off/unplug the microSD card during the system upgrade process.
- Please delete the upgrade file from the Micro SD card after the upgrade is completed.

TROUBLESHOOTING

- The device cannot be turned on.
The battery runs out, please charge the battery.
- Green power indicator is on, but the screen is black.
Screen is standby, short press power button  to awake the screen.
- The device cannot be powered by an external power supply.
 - 1.Type-C cable is damaged, please replace a new cable.
 - 2.Please check whether the external power supply is insufficient.
- The screen is too dark.
Short press  to increase brightness.
- The icons on screen are clear but image is blurry.
 - 1.Rotate the objective lens ring to adjust the focus.
 - 2.Wipe off the dust or dirt on the optical surface.
- The device can not connect to the computer.
 1. Check whether the port is loose.
 2. Please make sure the Micro SD card is in NV500. Connect the device to the computer first, then power on the device.
- After mounting the lens, the icon on the main interface still shows 
Please make sure the electrical contacts and Bayonet Mount (Body) are clean and free of foreign objects.